

United States Department of the Interior
National Park Service

NATIONAL REGISTER OF HISTORIC PLACES
REGISTRATION FORM

This form is for use in nominating or requesting determinations for individual properties and districts. See instructions in How to Complete the National Register of Historic Places Registration Form (National Register Bulletin 16A). Complete each item by marking "x" in the appropriate box or by entering the information requested. If any item does not apply to the property being documented, enter "N/A" for "not applicable." For functions, architectural classification, materials, and areas of significance, enter only categories and subcategories from the instructions. Place additional entries and narrative items on continuation sheets (NPS Form 10-900a). Use a typewriter, word processor, or computer, to complete all items.

1. Name of Property

historic name Woodville School
other names/site number DHR File No. 036-5045

2. Location

street & number 4310 George Washington Memorial Highway not for publication N/A
city or town _____ vicinity N/A
state Virginia code VA county Gloucester code 073 Zip 23131

3. State/Federal Agency Certification

As the designated authority under the National Historic Preservation Act of 1986, as amended, I hereby certify that this X nomination ___ request for determination of eligibility meets the documentation standards for registering properties in the National Register of Historic Places and meets the procedural and professional requirements set forth in 36 CFR Part 60. In my opinion, the property X meets ___ does not meet the National Register Criteria. I recommend that this property be considered significant ___ nationally ___ statewide X locally. (___ See continuation sheet for additional comments.)

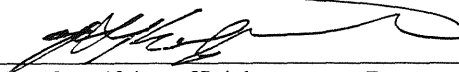
 _____
Signature of certifying official Date 12/23/03
Virginia Department of Historic Resources
State or Federal agency and bureau

In my opinion, the property ___ meets ___ does not meet the National Register criteria. (___ See continuation sheet for additional comments.)

Signature of commenting or other official Date

State or Federal agency and bureau

4. National Park Service Certification

I, hereby certify that this property is:
___ entered in the National Register
___ See continuation sheet.
___ determined eligible for the
National Register
___ See continuation sheet.
___ determined not eligible for the National Register
___ removed from the National Register
___ other (explain): _____

Signature of Keeper

Date of Action

5. Classification

Ownership of Property (Check as many boxes as apply)

- private
- public-local
- public-State
- public-Federal

Category of Property (Check only one box)

- building(s)
- district
- site
- structure
- object

Number of Resources within Property

Contributing	Noncontributing	
<u> 2 </u>	<u> 0 </u>	buildings
<u> 0 </u>	<u> 0 </u>	sites
<u> 1 </u>	<u> 1 </u>	structures
<u> 0 </u>	<u> 0 </u>	objects
<u> 3 </u>	<u> 1 </u>	Total

Number of contributing resources previously listed in the National Register 0

Name of related multiple property listing (Enter "N/A" if property is not part of a multiple property listing.)

 N/A

6. Function or Use

Historic Functions (Enter categories from instructions)

Cat: Education Sub: School

Current Functions (Enter categories from instructions)

Cat: VACANT/not in use Sub:

7. Description

Architectural Classification (Enter categories from instructions)

Late 19th and 20th century Revivals

Materials (Enter categories from instructions)

foundation Brick

roof Asphalt

walls Wood

other Glass

Narrative Description (Describe the historic and current condition of the property on one or more continuation sheets.)

8. Statement of Significance

Applicable National Register Criteria (Mark "x" in one or more boxes for the criteria qualifying the property for National Register listing)

- A Property is associated with events that have made a significant contribution to the broad patterns of our history.
- B Property is associated with the lives of persons significant in our past.
- C Property embodies the distinctive characteristics of a type, period, or method of construction or represents the work of a master, or possesses high artistic values, or represents a significant and distinguishable entity whose components lack individual distinction.
- D Property has yielded, or is likely to yield information important in prehistory or history.

Criteria Considerations (Mark "X" in all the boxes that apply.)

- A owned by a religious institution or used for religious purposes.
- B removed from its original location.
- C a birthplace or a grave.
- D a cemetery.
- E a reconstructed building, object or structure.
- F a commemorative property.
- G less than 50 years of age or achieved significance within the past 50 years.

Areas of Significance (Enter categories from instructions)

Education, Ethnic Heritage: Black

Period of Significance 1923 - 1942

Significant Dates 1923

1942

Significant Person (Complete if Criterion B is marked above)

N/A

Cultural Affiliation N/A

Architect/Builder Unknown

Narrative Statement of Significance (Explain the significance of the property on one or more continuation sheets.)

9. Major Bibliographical References

Bibliography

(Cite the books, articles, and other sources used in preparing this form on one or more continuation sheets.)

Previous documentation on file (NPS)

preliminary determination of individual listing (36 CFR 67) has been requested.

previously listed in the National Register

previously determined eligible by the National Register

designated a National Historic Landmark

recorded by Historic American Buildings Survey # _____

recorded by Historic American Engineering Record # _____

Primary Location of Additional Data

State Historic Preservation Office

Other State agency

Federal agency

Local government

University

Other

Name of repository: _____

10. Geographical Data

Acreage of Property 1.01

UTM References (Place additional UTM references on a continuation sheet)

Zone Easting Northing Zone Easting Northing

1 18 0365738 4131783 2 _____

3 _____ 4 _____

____ See continuation sheet.

Verbal Boundary Description (Describe the boundaries of the property on a continuation sheet.)

Boundary Justification (Explain why the boundaries were selected on a continuation sheet.)

11. Form Prepared By

name/title: David A. Brown, Thane H. Harpole, and Anthony W. Smith

Organization: DATA Investigations date July 29, 2003

street & number: 3267 Kings Creek Rd telephone (804) 684-0865

city or town Hayes state VA zip code 23072

Additional Documentation

Submit the following items with the completed form:

Continuation Sheets

Maps

- A USGS map (7.5 or 15 minute series) indicating the property's location.
- A sketch map for historic districts and properties having large acreage or numerous resources.

Photographs

Representative black and white photographs of the property.

Additional items (Check with the SHPO or FPO for any additional items)

Property Owner

(Complete this item at the request of the SHPO or FPO.)

name David L. Peebles

street & number P.O. Box 417 telephone (804) 642-3460

city or town Ordinary state VA zip code 23131

=====
Paperwork Reduction Act Statement: This information is being collected for applications to the National Register of Historic Places to nominate properties for listing or determine eligibility for listing, to list properties, and to amend existing listings. Response to this request is required to obtain a benefit in accordance with the National Historic Preservation Act, as amended (16 U.S.C. 470 et seq.).

Estimated Burden Statement: Public reporting burden for this form is estimated to average 18.1 hours per response including the time for reviewing instructions, gathering and maintaining data, and completing and reviewing the form. Direct comments regarding this burden estimate or any aspect of this form to the Chief, Administrative Services Division, National Park Service, P.O. Box 37127, Washington, DC 20013-7127; and the Office of Management and Budget, Paperwork Reductions Project (1024-0018), Washington, DC 20503.

Section 7 Page 1

7. Summary Description:

The Woodville School is a single story, wood framed, Rosenwald building that sits on a one-acre parcel of land adjacent to U. S. Route 17 in Gloucester County, Virginia. This school was constructed in 1923 and was converted to residential use following its sale by the Gloucester County School Board in 1942. The exterior appearance of the school has changed little since it was first built, with the exception of some fenestration changes and the addition of two doors on the west façade. The interior has received more extensive alterations, primarily in the 1940s, but the majority of the original fabric remains intact, including floors, doors, and vertical wainscoting. Two contributing outbuildings that may have served as a guesthouse or additional school building and a small shed, are located to the southwest of the main building. Woodville School is Gloucester County's only well-preserved early 20th-century African American school building, and is a highly visible landmark of Gloucester's history.

Detailed Exterior Description

The existing Woodville School building conforms to a typical Rosenwald school plan. It is a high one-story symmetrical frame structure measuring 63.5 feet by 28.5 feet and sheathed in white painted clapboard. Originally constructed on brick piers, they have now been connected with a continuous brick footing. The 5-bay east façade is composed of a sealed porch with a broken pediment gable capping two sets of double nine-over-nine single-hung sash windows. An attic vent, brick landing, and a set of stairs with an iron railing leading to a central door complete the porch elevation. Each wing of the east façade contains two sets of six-over-six single-hung sash windows, the innermost being a single window and those closest to the gable ends being paired windows. The north and south gables replicate the porch's broken pediment and are both penetrated by an attic vent and two nine-over-nine single-hung sash windows. The west (or rear) elevation contains four paired, equally spaced nine-over-nine single-hung sash windows. A central door and a door adjacent to the southwest corner, each with brick stairs and landings, provide access to the back yard. The roof is covered in asphalt shingle and is penetrated approximately seventeen feet from each gable by an interior brick chimney.

Woodville sits on a small landscaped lot next to Route 17 in Gloucester County's development corridor. In addition to its importance as an African-American school, Woodville School is a highly visible monument to Gloucester County's diverse history. Its designation on the National Register will enhance the recognition of local history and historic resources along the quickly changing Route 17 corridor.

**United States Department of the Interior
National Park Service**

**National Register of Historic Places
Continuation Sheet**

**Woodville School
Gloucester County, VA**

Section 7 Page 2

Changes to the exterior of the building have not been extensive and are most apparent in the fenestration. A photograph of the building from the early 20th century (post 1923) reveals that the two windows on the south gable, and likely those on the north, are not original. The west elevation originally contained two equally spaced sets of six nine-over-nine single-hung sash windows, as shown in the attached photograph (see Woodville School Historic Photo). The two central windows from each set were removed later in the 20th century. The dimensions and construction of these windows match those now present on the north and south gables and were likely moved there during the interior alteration of the school during the 1940s. The present owner removed a small concrete block furnace shed, added to the west elevation between the two northernmost sets of windows during the second half of the 20th century, in 2002. Traces of fire and smoke damage were present in the vicinity of the furnace behind this addition, as well as evidence of original framing for the removed set of windows. Other changes to the exterior include the addition of chimneys, the two doors on the west façade, the three machine-made brick stairs and landings leading to the doors, and a continuous brick foundation filling the spaces between the original brick piers. The south door on the west elevation is a five-panel wood and glass door. The north door on the west elevation has three panels of wood and glass. The front door on the east façade is a two-panel wood and glass door, with a decorative leaded glass window. The exterior of the building retains many of its original 1923 elements, while the majority of the changes were completed during the conversion of the school into a house during the 1940s.

Detailed Interior Description

The original interior layout of the first floor consisted of a symmetrical double pile plan of four main rooms split by a central hall. An enclosed porch on the east façade is also original. The primary interior alterations consisted of the division of each of the four main rooms into two rooms each, with the northwest rooms being further partitioned to create a bathroom and closet. Additional alterations include the conversion of the southwest corner room into a kitchen, and the addition of two chimneys along the axis of the building where each set of four rooms converged.

The original wood floors remain intact and the majority of the original vertical tongue and groove wainscoting is preserved beneath modern drywall. Removal of a portion of the baseboard along the walls of the two southeast rooms uncovered no evidence of the wainscoting along the partition wall, proving that it is a later addition. The baseboards, which had not been removed in the other rooms,

**United States Department of the Interior
National Park Service**

**National Register of Historic Places
Continuation Sheet**

**Woodville School
Gloucester County, VA**

Section 7 Page 3

are plain and appear to be original. Modern drop ceilings were installed in the kitchen and porch, obscuring the approximately 12-foot ceilings that are intact and visible in the rest of the building. The plain crown molding applied on top of the drywall throughout the building was likely added during the conversion of the school into a house. All four original doorways to the central hall have original five-panel wooden doors. All of the other doors are more modern additions, including the door dividing the foyer/porch from the central hall.

Alterations to the floor plan largely occurred during the conversion of the building from a school into a house after the Gloucester County School Board sold the building in 1942. By 1950, the Stubbs family was living in the converted school and the necessary additions of a kitchen, heating system and bedrooms were probably completed by then. Despite the significant 1940s alterations, the original fabric of the building appears fairly intact. The majority of the changes involved adding to the interior design of the building without removing or destroying much of the original detailing.

Outbuildings

There is a contributing single story two-bay wood framed building 75 feet southwest of the school. The building's construction date is unknown though elements appear contemporary with the main structure. Two six-pane fixed windows are asymmetrically placed on the east elevation, one on the west elevation, and an additional one on the north gable. A simple two-panel wooden door provides entry to the building from the south gable end. The interior is divided into an entranceway and main room, with a small closet or bathroom in the southeast corner. The building is set on concrete piers with an asphalt shingle roof and may have served as a teacher's house or guesthouse for visitors to the home or school.

A small shed structure stands just behind a two-hole out-house, both in dilapidated condition about 50 feet west of this building. The contributing shed is a simple wood frame construction with a front gable asphalt shingle roof, which is contemporary with the main building. There is a single wooden door for entry. There is also a non-contributing plywood two-hole outhouse capped with a metal roof, which appears to be of modern construction.

United States Department of the Interior
National Park Service

National Register of Historic Places
Continuation Sheet

Woodville School
Gloucester County, VA

Section 8 Page 4

8. Statement of Significance

Summary

The Woodville School is an important monument to the efforts of local African-Americans and the Rosenwald Fund to provide a quality education for black children in the early 20th century. It represents a type of school once prevalent throughout Virginia and the southern states that is now facing increasing threats. Historic school buildings, especially those built for African Americans, are rare survivals in this area and Woodville is a unique Gloucester County landmark. This property is nominated under Criterion A, symbolizing the desire of a rural African-American community to educate their children during the first half of the 20th century.

Historical Background

The early history of the Woodville School, along with the history of African-American education in Gloucester County, is incomplete and sparsely documented. An 1857 plat of the property on which the Woodville School now rests indicates its ownership by Col. Robert Thruston but does not indicate any structures on the property.¹ An 1886 plat shows the division of this property into its current one-square-acre form as part of a sale from Col. Robert Thruston to the Abingdon School District "as a location for Public School col'd," though no building is indicated as being present at that time.² A 1912 map by R. A. Folkes ("Gloucester County") indicates a "colored school" employing two teachers near the location of the current Woodville School building. In August of 1922 the individual parish school districts of Gloucester County (Abingdon, Ware, and Petsworth) were consolidated into the Gloucester County School Board and their properties were transferred accordingly.³ It was apparently soon thereafter that the current Woodville School building was built.

The 1932 Virginia Construction Report indicates a construction date of 1923. This apparently indicates that the building shown on the 1912 map was replaced by a new Rosenwald School (the Woodville School building) in 1923 or soon thereafter.

Section 8 Page 5

**United States Department of the Interior
National Park Service**

**National Register of Historic Places
Continuation Sheet**

**Woodville School
Gloucester County, VA**

The early 20th century was a time of great change in the United States. The pressures of providing programs for African-American families, who were not yet prospering in their recently gained independence following centuries of enslavement, were mounting without the funding necessary to ensure their success. Whites continued to dominate local and state government positions and often funneled disproportionately larger amounts of funding towards white schools, leaving black schools without the funding necessary to provide a comparable education to their students. The President of the Sears, Roebuck Company, Julius Rosenwald, established the Rosenwald Fund in 1918 in order to help redress educational deficits facing the African-American community throughout the rural south. The Rosenwald Fund contributed more than \$4.3 million to the Rosenwald School Program through 1938 and more importantly, these funds were matched by African-Americans (\$4.7 million), underlining the strong sense of community support for these educational programs.⁴

The Rosenwald School Fund helped establish hundreds of new schools in Virginia and made major improvements to existing "colored schools" throughout the Commonwealth. The Rosenwald Funds were an impetus for African-American communities to raise "matching funds." The majority of funding for these schools came from the African-American community itself, which often provided more money than the Rosenwald Fund, State, and Local governments combined. The Woodville School had a total construction cost of \$3,500, of which the local African-American Community provided \$2,500. The Rosenwald Fund provided \$700 and the local Gloucester government provided \$300.

The Woodville School is representative of the Rosenwald-type schools that were constructed throughout the southern United States. These schools were built following certain guiding principals that aimed to maximize the lighting, safety and efficiency of each school while keeping costs to a minimum. Woodville School was built on the main road through Gloucester County. It is oriented directly north south with the tall windows on the east and west facades to allow maximum light to reach the classrooms. The interior boasted lofty ceilings, wood floors, vertical wainscoting, and a small, enclosed porch as specified in the Community School Plans issued by the Rosenwald Fund administrators.⁵ These details were carefully planned by Rosenwald Fund architects to provide African-American students with a clean, bright, and functional educational atmosphere.

The history of the African-American experience in Gloucester County in the late 19th and early 20th centuries is characterized by the concerted efforts of local citizens to ensure that freed slaves and

**United States Department of the Interior
National Park Service**

**National Register of Historic Places
Continuation Sheet**

**Woodville School
Gloucester County, VA**

Section 8 Page 6

their children could obtain an education and/or training in a variety of fields. Amongst the most notable of these men and women were Thomas C. Walker and Robert Russa Moton. T. C. Walker founded the Gloucester Industrial School in 1885 at nearby Cappahosic to train qualified teachers in industrial and architectural fields. Mr. Walker was a founding member of the Educational Association, an organization formed for and by the African-American community. Robert Russa Moton became principal of the Tuskegee Institute upon the death of Booker T. Washington in 1915.

His efforts on behalf of African-American education in the 1930's were legendary and resulted in the establishment of a training camp for black military officers and a black combat division.⁶ The Robert Russa Moton house, Holly Knoll, in Gloucester County was the site of the founding of the United Negro College Fund in 1944. Holly Knoll is a National Historic Landmark, a testament to the importance of the efforts of African-Americans of the early 20th century to establish quality schools and training programs at a time when local government funding for such programs was at a minimum.⁷ It is to the spirit of these men and women that the Woodville School pays tribute. It is an irreplaceable monument to the refusal of a minority group to accept unequal treatment, and to the Rosenwald School Program, which provided impetus, guidance, and funding to aid their endeavor.

Most of these "Rosenwald Schools" are unfortunately gone, and many more are currently under a variety of physical and monetary threats. The location of these schools in the southern United States is reflective of the demographic patterns of African-Americans at the turn of the 20th century. Throughout the South, interest in these schools is increasing and efforts to save those that remain are becoming the focus of preservation groups studying buildings and sites relating to the African-American experience in the South during the early 20th century. Because of their unique architectural signature, the states of Alabama and Louisiana have already initiated surveys of their remaining Rosenwald structures, with the former developing a traveling exhibit in order to increase public understanding of the history of these important schools. The state of Mississippi listed all Rosenwald schools on its 10 Most Endangered List of 2001 and the National Trust for Historic Preservation placed Rosenwald schools on its list of most endangered places in 2002.

Recently, the National Trust's Southern Office established the Rosenwald School Initiative in order to help fund efforts to promote the history of the Rosenwald Schools and to generate interest in preservation measures for these endangered buildings. Their investment in such an initiative underscores the importance of studying early 20th-century institutional architecture and presenting

Section 8 & 9 Page 7

**United States Department of the Interior
National Park Service**

**National Register of Historic Places
Continuation Sheet**

**Woodville School
Gloucester County, VA**

to the public African-Americans' efforts to ensure the educational well being of their community.

After serving as a school for many years, George W. Marshall received the "Woodville Colored School Property" from the Gloucester School Board in 1942 for \$450 by order of the Chancery Court.⁸ Mr. Marshall, a local real estate speculator, sold the property in 1943 to James and Edith Stubbs.⁹ A group of Mr. Stubbs' children and relatives sold the property to David Peebles in October of 2001. The only accurate plat of the building's location on the property was drafted as part of this sale (see attached plat).¹⁰ Currently, the property is listed as lot 45-412 on Gloucester County tax maps.

**United States Department of the Interior
National Park Service**

**National Register of Historic Places
Continuation Sheet**

**Woodville School
Gloucester County, VA**

Bibliography

Bagby, George. "William G. Price and the Gloucester Agricultural and Industrial School," *Virginia Magazine of History and Biography*, 2000, 108, no. 1, 45-84.

Folkes, R. A. *Gloucester County, 1912*. Colonial Williamsburg Foundation Special Collections, Williamsburg.

Gloucester County Circuit Court. Deed Books, Plat Books, Land Tax Books

Hanchett, Thomas W. "The Rosenwald Schools and Black Education in North Carolina," *The North Carolina Historical Review*, 1988, LXV, No. 4, 387-444.

Ketchum, Sarah E. *Education in Gloucester County, Virginia, 1860-1985*. Unpublished U. S. History Honors paper, on file at Gloucester County Public Library, 1985.

Loth, Calder, ed. *Virginia Landmarks of Black History: Sites on the Virginia Landmarks Register and the National Register of Historic Places*. Charlottesville: University Press of Virginia, 1995.

McCartney, Martha W. *With Reverence for the Past: Gloucester County, Virginia*. Richmond: The Dietz Press, 2001.

Morrill, Dan L. *McClintock Rosenwald School and the Newell Rosenwald School*. Charlotte-Mecklenburg Historic Landmarks Commission
<http://www.cmhpf.org/S&RR/McClintockNewellRosen.html>, 1987.

Walker, Thomas Calhoun. *The Honey-Pod Tree*. New York: John Day Company, 1958.

**United States Department of the Interior
National Park Service**

**National Register of Historic Places
Continuation Sheet**

**Woodville School
Gloucester County, VA**

Section 10 Page 10

Verbal Boundary Description

The Woodville School land tract consists of 1.01 acres of land and runs parallel to U.S. Route 17 (George Washington Memorial Highway). The property is parcel number 412 on map 45. The property is bounded on the east by United States Route 17, George Washington Memorial Highway. The parcel runs 209.38 feet south from the northeast corner of the property on U.S. Route 17 to an iron rod that demarcates the property from the land of Clyde and Eliza Green, owners of parcel 411 to the south. From this point the property continues west 211 feet along the Green's property to a pipe. This marker demarcates the Woodville School tract from the property of Erin Snyder Dixon, the owner of parcel 413 to the west. The property continues from this point north 209.30 feet along Dixon's property to another pipe. This marker demarcates the Woodville School tract from the property of Mary C. Snyder, Lorraine S. Crandol Trust/Trustee, the owners of parcel 407 to the north. The property continues from this point east 210.68 feet to the starting point along U.S. Route 17.

Boundary Justification

The property boundaries include the complete extent of the historic property associated with Woodville School. This includes the historic school and surrounding supporting structures. The boundaries enclose the entire parcel owned by the current property owners and are bounded on the east by U.S. Route 17 and by adjacent property owners on the other three sides.

United States Department of the Interior
National Park Service

National Register of Historic Places
Continuation Sheet

Woodville School
Gloucester County, VA

Section 10 Page 11

Photograph Key

All photos Name: Woodville School, 036-5045
County: Gloucester County
State: Virginia
Photographer: David A. Brown
Location of negatives: Virginia Department of Historic Resources and
DATA Investigations, LLC
3267 Kings Creek Road
Hayes, VA 23072

Photo #1 Date: 12/11/01
Negative #: 18742
Description: Exterior, looking southwest at east façade

Photo #2 Date: 12/11/01
Negative #: 18742
Description: Exterior, looking northwest at east facade

Photo #3 Date: 12/11/01
Negative #: 18742
Description: Exterior, looking south at north gable end

Photo #4 Date: 12/11/01
Negative #: 18742
Description: Exterior, looking northeast at west façade and south gable end

Photo #5 Date: 12/11/01
Negative #: 18742
Description: Exterior, looking west at east façade of outbuilding

Photo #6 Date: 6/22/02
Negative #: 18742
Description: Interior, looking northeast at east interior wall of porch

Section 10 Page 12

**United States Department of the Interior
National Park Service**

**National Register of Historic Places
Continuation Sheet**

**Woodville School
Gloucester County, VA**

- Photo #7 Date: 6/22/02
 Negative #: 18742
 Description: Interior, looking northwest at north partition wall of southwest corner room
- Photo #8 Date: 6/22/02
 Negative #: 18742
 Description: Interior, looking east through center hall at interior porch door
- Photo #9 Date: 6/22/02
 Negative #: 18742
 Description: Interior, looking north from southeast room through the center hall to the partition wall of northwest corner room
- Photo #10 Date: 6/22/02
 Negative #: 18742
 Description: Interior, looking southwest at closet in southwest corner of northwest corner room
- Photo #11 Date: 6/22/02
 Negative #: 18742
 Description: Interior, looking southeast at chimney and flue hole in southeast corner of northwest corner room

United States Department of the Interior
National Park Service

National Register of Historic Places
Continuation Sheet

Woodville School
Gloucester County, VA

Sections 8&9 Page 8

Endnotes

¹ Gloucester County Plat Book 2, 29.

² Gloucester County Plat Book 3, 100.

³ Gloucester County Deed Book 47, 42.

⁴ Dr. Dan L. Morrill, *McClintock Rosenwald School and the Newell Rosenwald School*. Online report from Charlotte-Mecklenburg Historic Landmarks Commission, 1987, <http://www.cmhpf.org/S&RR/McClintockNewellRosen.html>, 2,3,21.

⁵ Ibid. 6-8.

⁶ Martha W. McCartney, *With Reverence for the Past: Gloucester County, Virginia*. (The Dietz Press, Richmond, 2001), 242.

⁷ Calder Loth, ed., *Virginia Landmarks of Black History: Sites on the Virginia Landmarks Register and the National Register of Historic Places*, (Charlottesville: University Press of Virginia, 1995).

⁸ Gloucester County Chancery Order Book 13, 440.

⁹ Gloucester County Deed Book 79, 362.

¹⁰ Gloucester County Clerk's Plat Book 24, 175

Woodville School

Projected Original Plan
1923/4

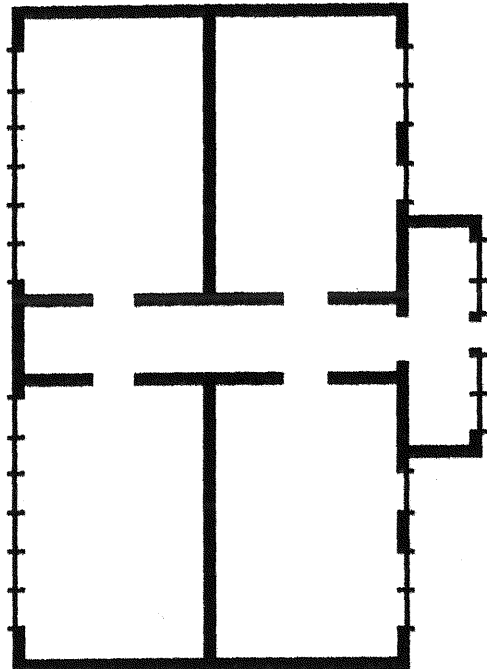

↑
North

Current Plan
2003

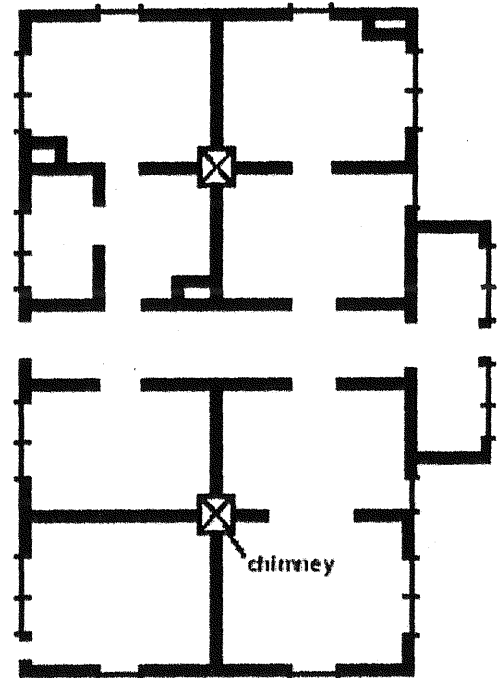

52-203	S 12°19'51" W	6.97'
90-39	S 01°47'30" E	16.40'
89-42	S 07°40'59" W	14.84'
88-41	S 08°56'45" E	12.53'
87-49	S 50°43'38" E	19.24'
114-40	S 19°55'09" E	10.67'
227-208	N 87°52'55" W	11.01'
228-204	N 85°06'40" W	8.85'

87-114	S 84°25'20" E	98.32'
114-90	N 05°34'05" E	215.92'
52-228	S 02°41'56" W	216.45'
52-227	S 02°41'56" W	297.23'
52-90	N 82°37'06" W	213.70'
90-89	N 85°32'32" W	205.53'
89-88	S 05°53'32" W	211.91'
88-87	S 84°25'20" E	108.38'
87-50	S 03°55'18" W	291.65'
50-51	S 86°29'52" E	328.24'
51-52	N 02°41'56" E	489.45'

MARY C. SNYDER;
LORRAINE S. CRANDOL; TRUST
L.R. #000005636; W.F. #990000655; D.B.430
P.26; C.P.B.22 P.532A-532E; D.B.254 P.752;
C.P.B.20 P.210; D.B.252 P.290; D.B.238
P.808 & 810; D.B.237 P.340 & 342; C.P.B.18
P.57 & 58; D.B.231 P.764 & 765; D.B.209 P.24;
D.B.202 P.732 & 734; D.B.170 P.51 & 100;
S.P.B.3 P.4 & 122; D.B.145 P.384; D.B.55 P.21;
D.B.40 P.125; D.B.33 P.458; D.B.30 P.216;
C.P.B.4 P.68; S.P.B.2 P.29 & 187
PARCEL 418 ON TAX MAP 45

C.P.B.20 P.201 & 210
C.P.B.22 P.532A-532E

MAG. NORTH OF 1890

ERIN SNYDER DIXON
D.B.360 P.719; C.P.B.21 P.899;
D.B.231 P.764; D.B.209 P.24;
D.B.146 P.384; D.B.40 P.125;
D.B.33 P.458; W.B."N" P.10;
C.P.B.4 P.68; S.P.B.2 P.29
PARCEL 413 ON TAX MAP 45

1.01 ACRES
PARCEL 412
ON TAX MAP 45

CLYDE and ELIZA GREEN
D.B.82 P.202-203 (P.203=PLAT);
D.B.33 P.458; S.P.B.2 P.29
PARCEL 411 ON TAX MAP 45

THIS PLAT IS A SURVEY OF PARCEL 412 ON TAX MAP 45.
PROPERTY SURVEYED IN THE NAME OF MILDRED PERCITIA
CARTER, IRVIN ELI GRAY, RONALD COLEMAN GRAY, GILBERT
BERNARD GRAY, WESLEY LEANDER STUBBS, MELVIN EDWARD
STUBBS AND AUDREY STUBBS MAY SEE W.F. #000000072;
D.B.91 P.67; D.B.79 P.362; D.B.71 P.486; D.B.33 P.458;
S.P.B.3 P.100; S.P.B.2 P.29; CHY.O.B.13 P.440; W.B."N"
P.10

(WOODVILLE SCHOOL)
PLAT OF 1.01 ACRES OF LAND
LOCATED IN ABINGDON DISTRICT
OF GLOUCESTER COUNTY, VIRGINIA

MAY 15, 2001

JAMES R. GRAY C.L.S.
GLOUCESTER, VIRGINIA

SCALE: 1"=40'
0 40 80



← US ROUTE 17 →
U.S. ROUTE 17
H/W P.B.3 P.5, 19, 75
NORTH →

TO GLOU. PT.
TO GLOU. C.H.

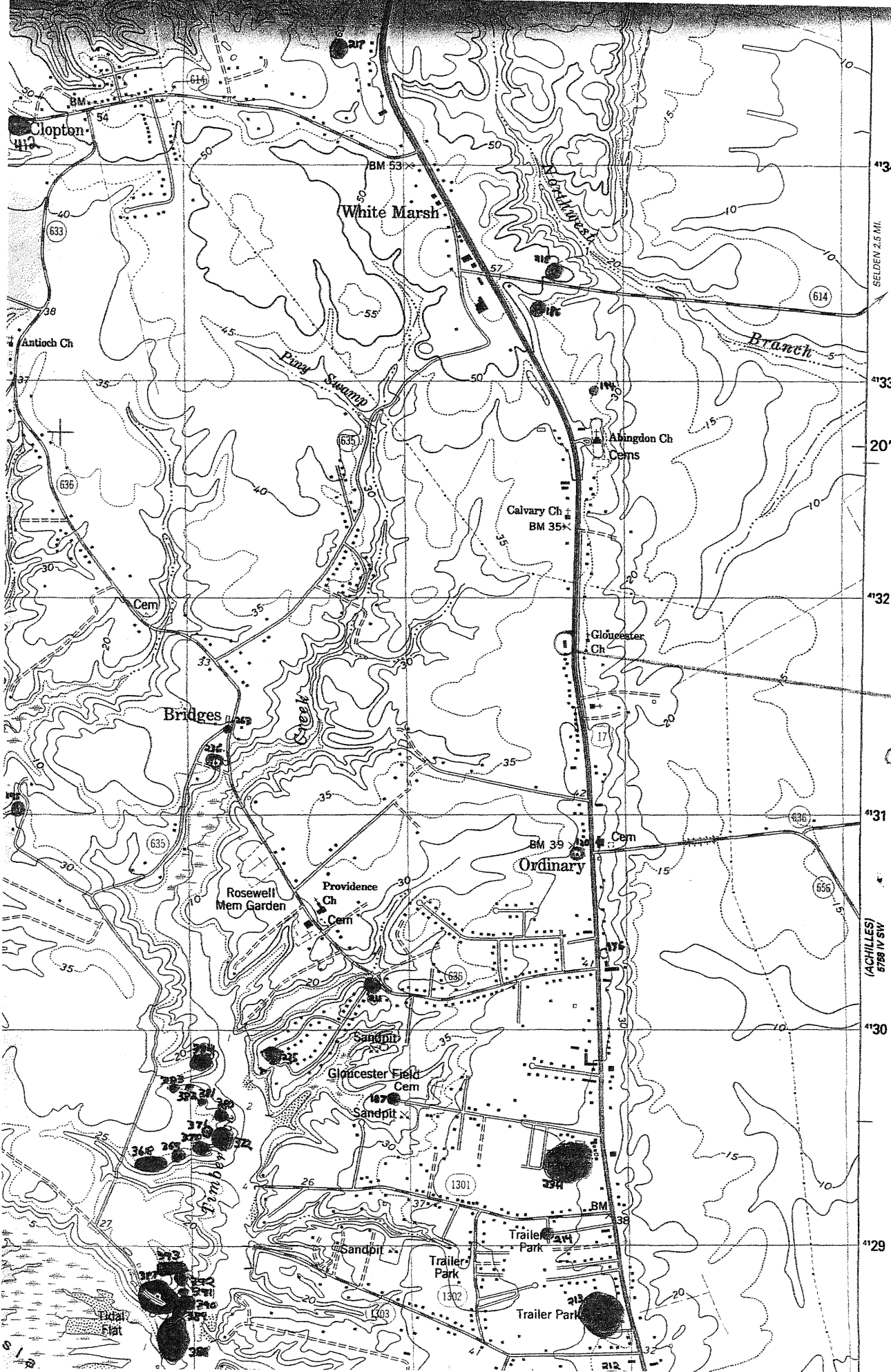

'34
 SELDEN 2.5 MI.
 '33
 20'
 '32
 '31
 '30
 (ACHILLES) 5788 IV SW
 '29

Woodville
 School
 Gloucester Co.,
 Virginia
 Clay Bank
 7.6-minute
 U.S.G.S.
 Quadrangle
 Zone 18
 Northing
 0365738
 Easting
 4131783