

United States Department of the Interior
National Park Service

National Register of Historic Places Registration Form

This form is for use in nominating or requesting determinations for individual properties and districts. See instructions in National Register Bulletin, *How to Complete the National Register of Historic Places Registration Form*. If any item does not apply to the property being documented, enter "N/A" for "not applicable." For functions, architectural classification, materials, and areas of significance, enter only categories and subcategories from the instructions.

1. Name of Property

Historic name: St. John's United Holy Church of America, Inc.

Other names/site number: DHR #127-7209

Name of related multiple property listing:
N/A

(Enter "N/A" if property is not part of a multiple property listing)

2. Location

Street & number: 1507 North 28th Street

City or town: Richmond State: VA County: Independent City

Not For Publication: Vicinity:

3. State/Federal Agency Certification

As the designated authority under the National Historic Preservation Act, as amended,

I hereby certify that this X nomination ___ request for determination of eligibility meets the documentation standards for registering properties in the National Register of Historic Places and meets the procedural and professional requirements set forth in 36 CFR Part 60.

In my opinion, the property X meets ___ does not meet the National Register Criteria. I recommend that this property be considered significant at the following level(s) of significance:

___ national ___ statewide X local

Applicable National Register Criteria:

X A X B X C ___ D

<p>_____ Signature of certifying official/Title: <u>Virginia Department of Historic Resources</u> State or Federal agency/bureau or Tribal Government</p>	<p>_____ Date</p>
<p>In my opinion, the property ___ meets ___ does not meet the National Register criteria.</p>	
<p>_____ Signature of commenting official:</p>	<p>_____ Date</p>
<p>_____ Title :</p>	<p>_____ State or Federal agency/bureau or Tribal Government</p>

St. John's United Holy Church of America, Inc.
Name of Property

City of Richmond, VA
County and State

4. National Park Service Certification

I hereby certify that this property is:

- entered in the National Register
 determined eligible for the National Register
 determined not eligible for the National Register
 removed from the National Register
 other (explain:) _____

Signature of the Keeper

Date of Action

5. Classification

Ownership of Property

(Check as many boxes as apply.)

- Private:
- Public – Local
- Public – State
- Public – Federal

Category of Property

(Check only **one** box.)

- Building(s)
- District
- Site
- Structure
- Object

St. John's United Holy Church of America, Inc.
Name of Property

City of Richmond, VA
County and State

Number of Resources within Property

(Do not include previously listed resources in the count)

Contributing	Noncontributing	
<u>1</u>	<u>0</u>	buildings
<u>0</u>	<u>0</u>	sites
<u>0</u>	<u>0</u>	structures
<u>0</u>	<u>0</u>	objects
<u>1</u>	<u>0</u>	Total

Number of contributing resources previously listed in the National Register 0

6. Function or Use

Historic Functions

(Enter categories from instructions.)

RELIGION/religious facility

Current Functions

(Enter categories from instructions.)

RELIGION/religious facility

St. John's United Holy Church of America, Inc.
Name of Property

City of Richmond, VA
County and State

7. Description

Architectural Classification

(Enter categories from instructions.)

LATE 19TH AND EARLY 20TH CENTURY REVIVALS/Colonial Revival

Materials: (enter categories from instructions.)

Principal exterior materials of the property: BRICK; METAL/tin

Narrative Description

(Describe the historic and current physical appearance and condition of the property. Describe contributing and noncontributing resources if applicable. Begin with a **summary paragraph** that briefly describes the general characteristics of the property, such as its location, type, style, method of construction, setting, size, and significant features. Indicate whether the property has historic integrity.)

Summary Paragraph

St. John's United Holy Church of America, Inc. is a one-story, three-bay, Colonial Revival church with a gable-front roof. Built in 1931-1932, the church, which is raised on an English basement, features six-course American-bond brick walls, strip pilasters at the corners, and sixteen-over-sixteen wood sash windows. A central one-bay Tuscan entry portico is reached by steps to each side. The portico incorporates a carefully detailed two-part architrave. A later addition extends to the south towards an alley. The interior of the sanctuary features rough textured plaster walls and a ceiling clad in decorative pressed metal featuring square coffers. The primary space in the English basement is an assembly hall with a regularly spaced double row of eight steel columns supporting the floor above. An added kitchen occupies the east corner, likely completed in 1942. A low concrete platform that forms a stage across a portion of the southeast end of the room was probably added at the same time as the kitchen. The concrete platform incorporates a baptismal basin with a cover. The church is the only resource on the property and is a contributing building. The building is in good condition and possesses high levels of historic integrity in terms of location, design, materials, workmanship, feeling, and association. Changes that have been made have generally respected its architectural integrity.

Narrative Description

St. John's United Holy Church of America, Inc.
Name of Property

City of Richmond, VA
County and State

Setting

The church faces directly onto North 28th Street in Richmond's East End. The neighborhood around the church is in transition. It was formerly a residential neighborhood. A hospital has been built directly across the street and a paved parking lot is directly adjacent to the church's southwest side. Other structures on the block have been demolished, leaving behind vacant lots.

Exterior

St. John's United Holy Church is a Colonial Revival, one-story, three-bay, brick, nave-plan church facing North 28th Street with a minimal setback. The gable-front roof is covered with block-tin standing-seam metal roofing. The molded wood box cornice includes returns in the front gable. The church features six-course American-bond walls, brick strip pilasters at the corners, and sixteen-over-sixteen wood sash windows. The windows are arranged in one bay to each side of the front entry and in four bays along each side. The windows are treated plainly, without jack arches or lintels, except on the front, where the two windows flanking the portico are treated with molded wood surrounds, molded sills, and classical cornices. The main entry, centrally located in the front wall, consists of an added pair of aluminum storefront doors topped by an original eighteen-light transom. The entry is protected by a one-bay Tuscan portico incorporating a carefully detailed two-part architrave. Concrete steps ascend to either side. The front of the porch is spanned by an original section of ornamental iron railing. The gable contains a bull's eye window with keystones at the top and bottom and to each side. The corner stone, located at the north corner, is inscribed with "St. John's - Holiness / Church / Organized-A.D. 1915 / Erected-A.D. 1931."

The building is raised on an English basement lit by three-over-three wood sash windows that are aligned with the first-floor openings. A tall brick chimney rises on the north side near the rear and a small flue rises on the south side near the center of that wall. A c. 1950 brick-clad concrete block addition was made to the rear of the church in the mid-twentieth century. The exterior is clad with running-bond brick. It features six-over-six sash windows, flush steel doors, and a large, off-center chimney on the rear wall. Two basement doors with concrete steps are located at the east and west ends of the north side of the original section and another on the north side of the rear addition. A modern wood canopy has been added over the western basement entry to provide rain protection for church members entering and exiting the basement. A double door provides an exit from the basement on the south side of the rear addition as well.

Interior

The sanctuary, located on the first floor, features rough-textured plastered walls defined by a series of projecting piers between the windows arranged along each side. The high ceiling rises within the roof to the bottom of the collar beams. The flat center section of the ceiling and the sloping areas that flank it on either side are clad in decorative pressed metal featuring square coffers. A central square contains a decorative medallion, while four pendant schoolhouse-style

St. John's United Holy Church of America, Inc.
Name of Property

City of Richmond, VA
County and State

light fixtures are suspended from decorative medallions that occupy the quadrants. The ceiling is bordered by a Greek anthemion frieze that runs around the entire room.

Woodwork in the sanctuary includes one-part architrave trim at the doors and windows and a molded baseboard. The windows are filled with opaque patterned pressed glass. The entry is located within a partial height frame vestibule that extends to one side to contain the stairs to the basement. A small office has been added to the side of the entry vestibule. The floor is carpeted. The first floor of the mid-twentieth century addition to the rear of the building contains a choir room and offices for church staff.

The basement interior is primarily made up of a rectangular assembly hall with plaster walls, linoleum and poured concrete flooring, and a pressed metal ceiling. The ceiling is made up of a grid of small square coffers with a small cove cornice around the outside walls. The basement is lit by regularly spaced schoolhouse light fixtures. A double row of eight steel columns supports the floor above. The two exterior doors on the northeast side are original. Small restrooms that occupied the corners in the northwest end have been enlarged. A large kitchen occupies the east corner. It was likely added in 1942. A low concrete platform that forms a stage across a portion of the southeast end of the room was probably added at the same time as the kitchen. The concrete platform incorporates a baptismal basin, now covered with plywood. A door at the center of the rear wall leads to the basement of the rear addition. A storage room occupies most of the addition, but an enclosed boiler room in the southeast corner of the addition contains a furnace that provides steam to radiators throughout the building.

Secondary Resources

There are no secondary resources.

Integrity Analysis

The location of the church is at the site purchased in the year the church was formed. The church has occupied the site and held services there continuously ever since. The initial frame structure was removed, and the current brick building was built in its place as funds were raised by the congregation. The setting around the site has changed, as the row houses surrounding the church on 28th Street have been demolished and a hospital constructed across the street in 1979.

The exterior design facing 28th Street remains as it was initially constructed. The original portions of the building remain visible on the northeast and southwest elevations; however, the elevations are elongated by the rear addition. The materials used on the exterior of the addition are consistent with the original; however, the location of the joint between the original and the addition is apparent due to aging and difference in workmanship. This is true on the interior as well with the sanctuary and entry vestibule remaining as original, but for the added church office and the choir area behind the altar. Both were paneled with wood at the time the office was added in the late 1970s or early 1980s, according to church members' recollection.

St. John's United Holy Church of America, Inc.
Name of Property

City of Richmond, VA
County and State

The feeling of the original 1931-1932 church has been largely maintained in the sanctuary and the basement level assembly hall, as the original construction and materials remain in place and in good condition. The addition is a discrete space on both levels, separated by walls from the original portion. There is clear demarcation between the original and later sections, however, care was taken to maintain the feeling of the original church congregational spaces. Given the overall integrity of the sanctuary, 28th street elevation and assembly area, the association with the period of the church's construction is maintained.

St. John's United Holy Church of America, Inc.
Name of Property

City of Richmond, VA
County and State

8. Statement of Significance

Applicable National Register Criteria

(Mark "x" in one or more boxes for the criteria qualifying the property for National Register listing.)

- A. Property is associated with events that have made a significant contribution to the broad patterns of our history.
- B. Property is associated with the lives of persons significant in our past.
- C. Property embodies the distinctive characteristics of a type, period, or method of construction or represents the work of a master, or possesses high artistic values, or represents a significant and distinguishable entity whose components lack individual distinction.
- D. Property has yielded, or is likely to yield, information important in prehistory or history.

Criteria Considerations

(Mark "x" in all the boxes that apply.)

- A. Owned by a religious institution or used for religious purposes
- B. Removed from its original location
- C. A birthplace or grave
- D. A cemetery
- E. A reconstructed building, object, or structure
- F. A commemorative property
- G. Less than 50 years old or achieving significance within the past 50 years

St. John's United Holy Church of America, Inc.
Name of Property

City of Richmond, VA
County and State

Areas of Significance

(Enter categories from instructions.)

ETHNIC HERITAGE: African American

SOCIAL HISTORY

ARCHITECTURE

Period of Significance

1931 – 1973

Significant Dates

1932

c. 1950

Significant Person

(Complete only if Criterion B is marked above.)

Forbes, James A. Jr.

Cultural Affiliation

N/A

Architect/Builder

Andrews, Anthony H.

Wooding, J.B.

St. John's United Holy Church of America, Inc.
Name of Property

City of Richmond, VA
County and State

Statement of Significance Summary Paragraph (Provide a summary paragraph that includes level of significance, applicable criteria, justification for the period of significance, and any applicable criteria considerations.)

The church, built in Richmond's Fairfield neighborhood in 1931-1932 by St. Johns United Holy Church, is locally significant under Criterion A in the area of Ethnic Heritage: African American as a building associated with an important African American church founded in the early twentieth century. Under Criterion B in the area of Social History, the property is locally significant for its association with Reverend Dr. James Forbes Jr., who served as minister to the church from 1965-1973 during the latter years of the Civil Rights movement and had an illustrious career that continued into the early 21st century. The property is also locally significant under Criterion C in the area of Architecture as an unusually well-preserved example of the type of building constructed by that denomination during the period of segregation. The congregation has carefully preserved significant elements of its original architectural form and materials. The property's period of significance is 1931-1973, beginning with construction of the current building's basement and temporary use for services and ending with the culmination of the pastorate of Reverend Dr. James Forbes Jr. Significant dates for the property are 1932, when the completed building replaced the congregation's original frame sanctuary, and c. 1950, when the rear addition was constructed. St. John's United Holy Church of America meets Criteria Consideration A for religious properties because it derives its primary significance from its historical importance under Criteria A and B, and from its architectural importance under Criterion C.

Narrative Statement of Significance (Provide at least **one** paragraph for each area of significance.)

Criterion A: Ethnic Heritage: African American

St. John's United Holy Church is an outgrowth of a powerful religious movement involving an experience of holiness which emerged out of the Methodist Church in the late nineteenth century. The Holiness Movement led to the secession of many Methodists to form separate denominations. Among the African-American churches, Holiness organizations emerged from African Methodist Episcopal, African Methodist Episcopal Zion, and Baptist congregations. The idea that underlay the movement, originating with John Wesley, the founder of Methodism, has been described as a doctrine of "a second work of grace" leading to perfection, a belief that spread among Wesleyan Methodists in the 1840s [e.g., Cooper, "Means of Grace as Formative Holiness"].

The United Holy Church of America, Inc. was founded in Method, North Carolina, in 1886. It is one of the oldest African American Pentecostal churches in the United States. It "emphasized the doctrines of justification, sanctification, and the Baptism of the Holy Spirit as evidenced by speaking in tongues, . . . [although] they were viewed more as Holiness churches than as Pentecostal" [DuPree xxxv]. Today, the church has congregations across the nation and around the world.

St. John's United Holy Church of America, Inc.
Name of Property

City of Richmond, VA
County and State

In Richmond, the St. John's congregation (sometimes identified as the St. John's Holiness Church), began with street preaching on the corner of 17th and Franklin streets. The Rev. William Fountain and his wife, who had moved across the James River from Manchester, organized a Holiness church at 29th and M streets in 1915. Rev. Fountain served as the first pastor. Future pastor and bishop William Clements "was drawn to the revival" at the original location. Later he and his wife Lena were moved to declare their faith at a service at the 29th Street location. The current site on the east side of North 28th Street was purchased in the same year and a frame church building constructed soon after. Congregational history indicates that this was the first new church in the city built by a black Pentecostal Church [St. John's United Holy Church, *1915-1980: 65 Years Church Anniversary Celebration, 1507 North 28th Street*].

The church has remained at the same site for more than 100 years to the present day. The ministers who served the church during the first half century included:

- Rev. William Fountain- 1915-1919
- Elder Joseph Silver- 1919-c1922
- Elder (later Bishop) William Clements- c1922-1960
- Rev. James Percy Jackson 1960-1965
- Rev. James A. Forbes, Jr 1965-1973
- Rev. Tyler C. Milner 1974-1979

African American churches have long been recognized for their significance in the lives of Virginia's African Americans. During the slavery era, enslaved African Americans were not free to choose a means of worship for themselves; whatever religious instruction made available to them was at the dictate of the slave owner. Free African Americans established churches during the colonial and early republic periods. In the Commonwealth, among those recently listed in the NRHP is First Baptist Church in Richmond (listed in 2017). Although the current church building dates to 1956, the congregation itself began in the early 1770s. From that date through the onset of the Civil War, African American churches functioned in difficult conditions as many whites opposed persons of color convening for any purpose without white supervision. After the Nat Turner Rebellion in 1831, Virginia's General Assembly passed laws requiring oversight of all African American churches by a white minister and forbade gatherings that were not supervised by at least one white person [Lewes and Hanbury, 11-12, 14].

After the Civil War, religious freedom ranked high among the cherished freedoms attained by newly emancipated African Americans and those who had been free prior to the war. For the first time in Virginia's history, African Americans engaged in self-determination in religious and funerary practices, which led to a proliferation of new denominations and congregations across the state. Well-known denominations, including the African Methodist Episcopal Church and Zion Baptist Church, flourished through the late 19th century up to the present day. African American worship traditions, such as a sense of celebration, gospel and improvisational music, community experience and uplift based on the felt presence of grace, and interactive prayer, are understood to be deeply rooted in African Americans' lived experiences from their antecedents

St. John's United Holy Church of America, Inc.
Name of Property

City of Richmond, VA
County and State

in Africa, the Middle Passage, slavery, emancipation, Jim Crow, civil rights victories, and continued evolution to the present day. From these experiences, African American congregations have developed a diverse array of practices, some of which are particular to a single denomination and other that are more broadly used. While churches based in the Pentecostal tradition, such as St. John's United Holy Church of America, are associated with the aforementioned traditions, other personal experiences are prioritized too. The spontaneous demonstrations of faith and grace, as experienced by Rev. Fountain and his wife and Bishop Clements and his wife, are examples of this aspect of the Pentecostal tradition [Jones, "African American Worship"].

The central role played by the African American church in community life is as a place that provided autonomy, religious freedom, social and recreational opportunities, and community organizing and uplift. These roles go beyond the exercise of religion to embrace civil, political, and economic freedoms, whether curtailed during the slavery era, wielded carefully during the racial terrorism that characterized the Jim Crow era, or flourishing as part of the Civil Rights movement. For these reasons, St. John's United Holy Church of America is locally significant in the area of Ethnic Heritage: African American for its century-long association with Richmond's African American community.

Criterion B: Social History

Reverend Dr. James A. Forbes Jr served as minister to the St. John's United Holy Church of America from 1965-1973 during the latter years of the Civil Rights movement. While serving as minister, Reverend Forbes also engaged in civic activism in support of Richmond's black community, including serving as president of the Urban League of Greater Richmond and as Campus Minister at Virginia Union University, among other leadership roles in Richmond organizations ["Reverend Dr. James A. Forbes Jr's Biography" *The History Makers*].

Forbes's biography and professional accomplishments are described on multiple websites, all of which appear to have used a common set of source material. He was born in 1935 in Burgaw, North Carolina. His parents were James Forbes Sr. and Mabel Clemons Forbes. The senior Forbes worked as a salesman and served as pastor of the Providence United Holy Church in Raleigh, North Carolina. Mabel Forbes worked as a domestic, one of the few employment options available to African American women during Jim Crow. One of eight children, the junior Forbes and his siblings were raised with the church as the center of their family life. In 1953, James Forbes Jr. left Raleigh to attend Howard University with the intention of becoming a medical doctor. Although he completed a degree in chemistry in 1957, Forbes abandoned medical school to attend Union Theological Seminary in New York City, where he completed a master of divinity degree in 1962 [*The History Makers*; Ring, Encyclopedia.com; CUCC Weekly News, July 12, 2019; The Riverside Church in the City of New York; The Connecticut Forum, October 14, 2005; Howard University Andrew Rankin Memorial Chapel, October 22, 2017; CUCC Weekly Enews, July 12, 2019].

St. John's United Holy Church of America, Inc.
Name of Property

City of Richmond, VA
County and State

Following his seminary studies, Forbes returned to North Carolina and worked briefly at his father's church. In 1962, he became a student intern at Olin Binkley Memorial Baptist Church in Chapel Hill, North Carolina, then went on to serve at Holy Trinity Church in Wilmington and St. Paul's Holy Church in Roxboro, North Carolina, before taking a position at St. John's United Holy Church of American in Richmond in 1965. While in Richmond, Forbes continued his academic studies by earning a clinical pastoral education certificate from the Medical College of Virginia in 1968. This was in addition to his community service and capacity as a campus minister at Virginia Union University [*The History Makers*; Ring, Encyclopedia.com; CUCC Weekly News, July 12, 2019; The Riverside Church in the City of New York; The Connecticut Forum, October 14, 2005; Howard University Andrew Rankin Memorial Chapel, October 22, 2017; CUCC Weekly Enews, July 12, 2019].

It appears that Forbes left Richmond to attend New York's Colgate Rochester Crozer Divinity School, where he attained a doctorate in ministry. Thereafter, Forbes's career continued on an illustrious trajectory that included returning to New York in 1976 to join the faculty at Union Theological Seminary, where he became the first Joe R. Engle Professor of Preaching in 1985 and being named the school's first Harry Emerson Fosdick Adjunct Professor of Preaching in 1989. The same year, he became the first African American minister at Riverside Church, one of the largest multicultural and interdenominational congregations in the United States [*The History Makers*; Ring, Encyclopedia.com; CUCC Weekly News, July 12, 2019; The Riverside Church in the City of New York; The Connecticut Forum, October 14, 2005; Howard University Andrew Rankin Memorial Chapel, October 22, 2017; CUCC Weekly Enews, July 12, 2019].

His academic and professional achievements, together with his prodigious energy and charismatic preaching style, led to him being dubbed a "preacher's preacher." *Ebony* magazine named Forbes one of America's "greatest Black preachers" in 1985 and 1993. In 1996, *Newsweek* recognized Forbes as one of the 12 "most effective preachers" in the English-speaking world. Forbes's intense style led to disputes with some congregation members at Riverside Church, but also contributed to his continuing rise as one of the most prominent ministers in the United States [Ari L. Goldman, May 18, 1992]. In 1995, Forbes's "Healing the Spirit of America" was edited from The Davison Lectures at Warren Wilson College. In 1998, he acted as the inaugural Luce Lecturer at Harvard Divinity School with an emphasis on urban ministry. The same year, he participated in the Department of Justice Roundtable on Your Violence at the White House and delivered the keynote address at the President's Initiative on Race meeting in New Orleans. Starting in 1992, Forbes served as co-chair of A Partnership of Faith, an interfaith organization composed of Protestant, Catholic, Jewish and Muslim communities in New York City. This aspect of his career perhaps reached its apex with his address to the 2004 Democratic National Convention. In 2007, he retired from Riverside Church as a senior emeritus minister, but then established a non-profit, non-partisan foundation, Healing of the Nations, with a focus on spiritual revitalization. Forbes accumulated 14 honorary degrees from Princeton University, Trinity College, Colgate University, and University of Richmond (Virginia). On the personal side, Forbes married Bettye Franks and the couple had one child, James Forbes III [*The History Makers*; Ring, Encyclopedia.com; CUCC Weekly News, July 12, 2019; The Riverside Church in the City of New York, Ari L. Goldman, May 18, 1992; The Connecticut Forum, October 14,

St. John's United Holy Church of America, Inc.
Name of Property

City of Richmond, VA
County and State

2005;Howard University Andrew Rankin Memorial Chapel, October 22, 2017; CUCC Weekly Enews, July 12, 2019].

Although Forbes preached at St. John's United Holy Church of America early in his career, between 1965-1973, this was a formative period that included his first long-term tenure as a minister, completion of a clinical pastoral education certificate from the Medical College of Virginia, and serving as a campus minister at the historically black Virginia Union University. The church is likely the property most closely associated with Forbes's career in Richmond and, based on information known to date, in all of Virginia. Consequently, St. John's United Holy Church of America is significant at the local level under Criterion B for its direct association with Forbes's contributions to Richmond in the area of Social History.

Criterion C: Architecture

When the congregation had outgrown its first building, the present church was commissioned and begun in 1931. The designer or architect is not known. The new building was constructed of brick and made use of modest Colonial Revival details. When the new church was built, the old church was purchased by Mt. Tabor Baptist and moved to their church site nearby on Fairmont Avenue. It is no longer standing. The mid-block site of St. John's Church historically was flanked by narrow lots filled with row houses. The sides of the new building were shielded by adjacent structures and, as a result, the principal architectural details were focused primarily on the church's street front facade.

Construction was phased as funds were raised. The basement was completed first and was covered with a temporary roof and used for church services in 1931. Fundraising was encouraged by the issuance of certificates showing that sponsors had purchased a brick to be used in the construction. The floor plan originally incorporated a shallow "choir stand" at the east end, flanked by a women's dressing room and restroom to the south and a small men's room and "finance room" to the north, linked by a narrow corridor across the rear containing a door to the exterior (see Figure 3). A platform containing the pulpit and official seating extended in front of the choir. The communion table was located on the floor in front of the pulpit. The basement contained a large meeting room. The northwest end of the basement housed the interior stair to the first floor and two small bathrooms. An enclosed room in the southeast corner apparently served as the boiler room. The furnace was served by a large chimney in the adjacent wall.

St. John's United Holy Church of America, Inc.
Name of Property

City of Richmond, VA
County and State

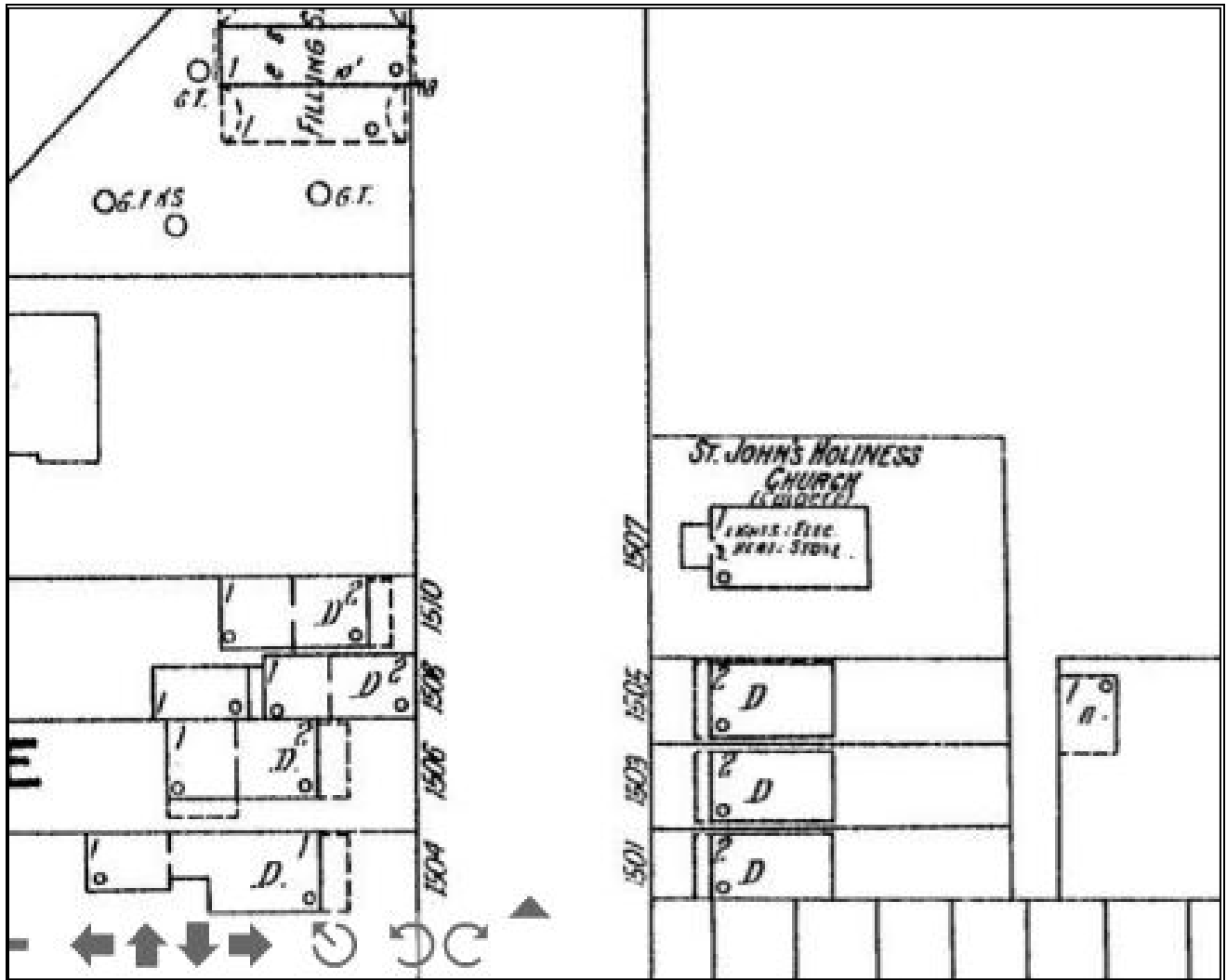

Figure 1: 1925 Sanborn Map. It shows the original church of 1915.

St. John's United Holy Church of America, Inc.
Name of Property

City of Richmond, VA
County and State

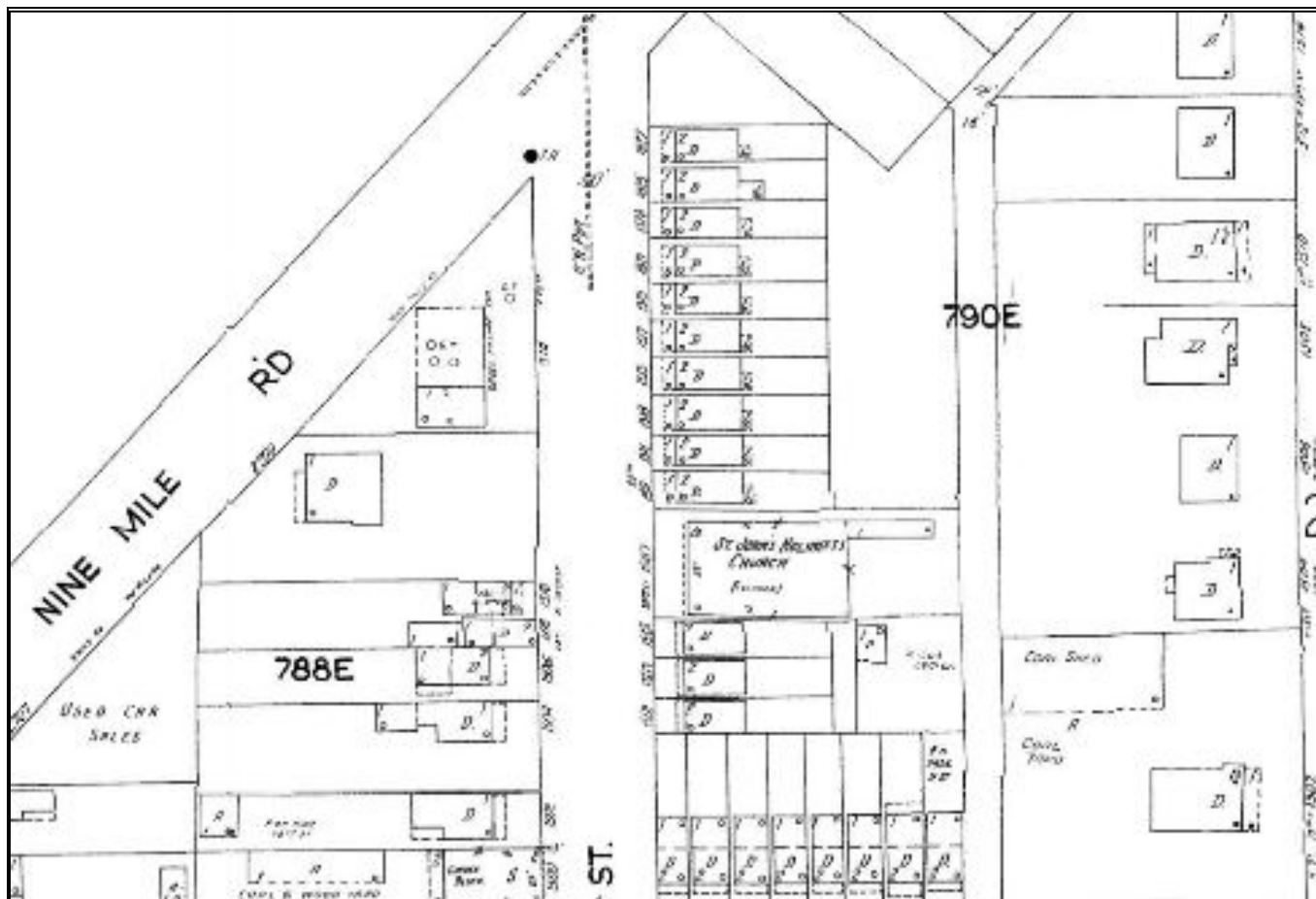

Figure 2: 1950 Sanborn Map. It shows the church of 1931, with the furnace room extending to the rear.

The church was subject to minor alterations in about 1942. A kitchen was added in that year in the former boiler room in the northeast corner. A concrete platform was extended along the rear wall beside the enclosure, incorporating a small baptismal pool. It seems likely that the present kitchen was the original location of the boiler or furnace room and that the furnace was placed in the new wing in order to make that space available. A long furnace room wing formerly extended to the east from the rear wall of the church. The boiler flue apparently extended into the main basement to enter the original furnace chimney. It had its own exterior entry, as would be typical for a furnace room.

At some point in the mid-twentieth century, the civil engineering firm of Anthony H. Andrews and his associate J. B. Wooding prepared plans for a wing to be built at the rear of the church [Undated drawings, St. John's United Holy Church, Inc.]. This c. 1950 addition, which was built according to the drawings, enlarged the pulpit area and the choir stand, while also adding a baptismal pool, additional restrooms, and a choir room. The former boiler room wing to the east was removed. An archway was added to mask the change in ceiling height between the sanctuary and the platform. Not much has been uncovered about either Andrews or Wooding. J. B.

St. John's United Holy Church of America, Inc.
Name of Property

City of Richmond, VA
County and State

Wooding drew the plans for a concrete-block addition to Abbots Hardware Store on Colley Avenue in Norfolk in 1951 [Norfolk Building Inspection Office Collection, Library of Virginia].

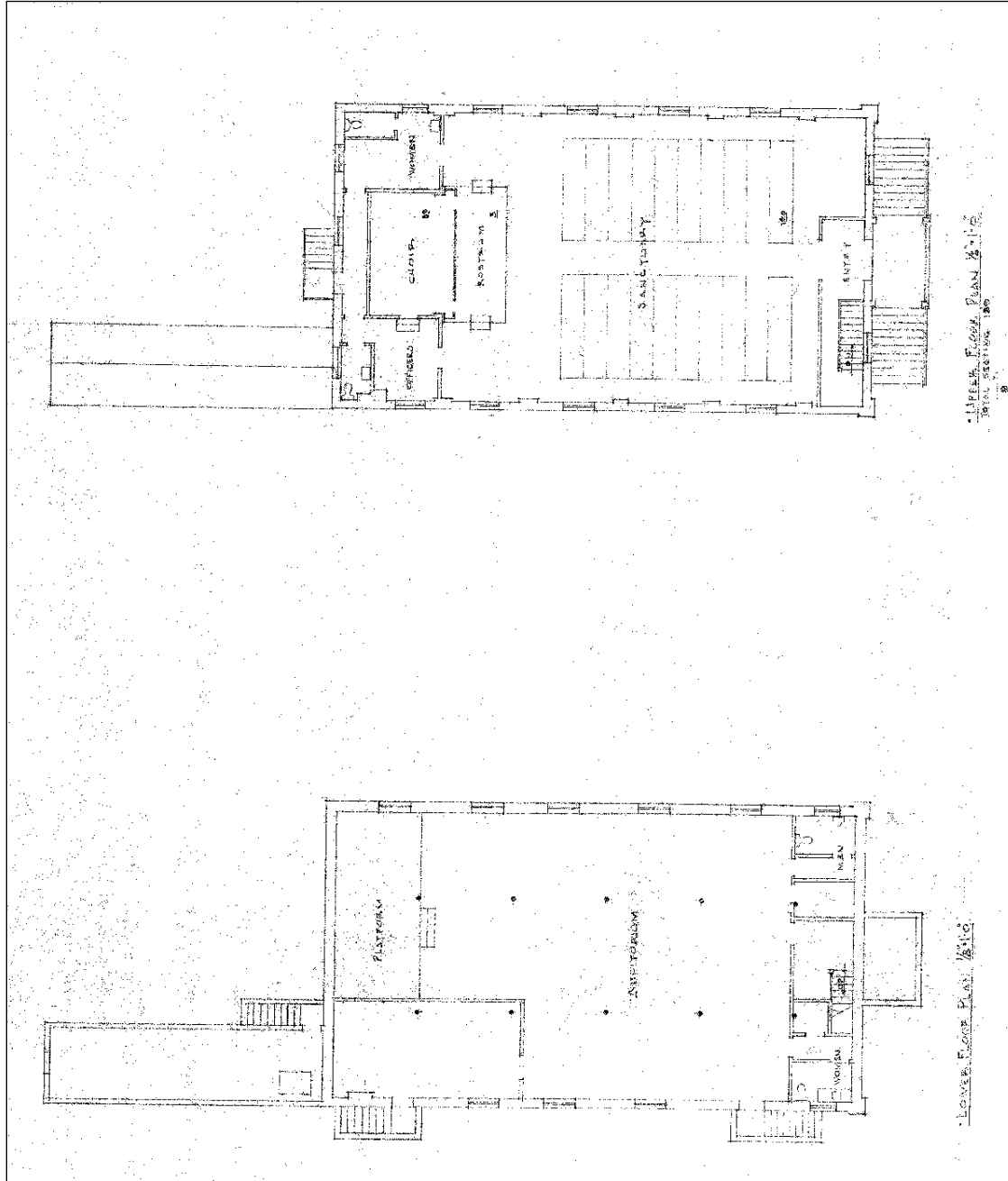

Figure 3: Anthony H. Andrews and J. B. Wooding, Existing Floor Plans, St. John's United Holy Church. No date (c. 1950) [St. John's United Holy Church]. These plans were drawn as part of the planning for the rear addition. They document the form of the church before the addition.

St. John's United Holy Church of America, Inc.
Name of Property

City of Richmond, VA
County and State

Alterations and Additions to the Church

The same firm also provided a proposal for a phased project at the church [Undated drawings, St. John's United Holy Church, Inc.]. This called for a wing to the side of the church that was never built. It would have included a fellowship and assembly room, a recreation room, nursery, kitchen, and restrooms in the basement and a pastor's study, restrooms, and assembly room with platform on the upper floor. The proposal also showed a rationalization of the circulation pattern at the front of the church. This included extending a narthex across the west end, moving the entrance to the north side at the northwest corner, and adding a large handicapped ramp on the north. It also included removing the existing interior basement stair, and replacing the front porch with a new projecting staircase. The changes proposed for the west end were never made.

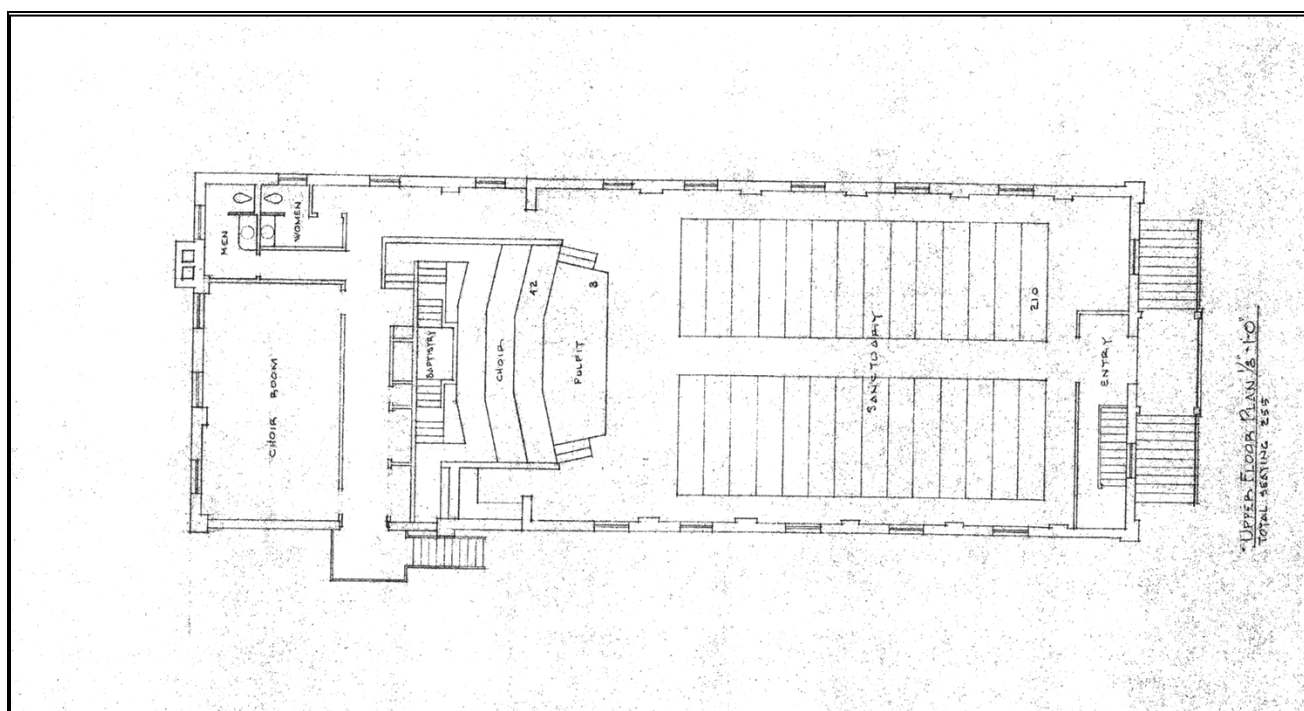

Figure 4: Anthony H. Andrews and J. B. Wooding, Detail, Proposal for Phase I of alterations and east end addition at St. John's United Holy Church, no date (c. 1950) [St. John's United Holy Church, Inc.].

Character-Defining Features

The character of the church as it faces North 28th street is defined by the Colonial Revival details, brickwork and the Tuscan order portico. The features give the church a stately presence on the street and a sense of permanence and prominence.

On the interior, the woodwork and frieze contribute to this sense of stateliness. The pressed metal ceiling is decorated with a repeating stylized nine-square based pattern that recalls a quilt. This pattern creates a sense of unity within the sanctuary, and is associated by the congregation with the nine-square quilt pattern used as a symbol for a safe haven during the time of the

St. John's United Holy Church of America, Inc.
Name of Property

City of Richmond, VA
County and State

Underground Railroad [phone interview with Janice Jones, chair of Church Facilities
Committee.]

St. John's United Holy Church of America, Inc.
Name of Property

City of Richmond, VA
County and State

9. Major Bibliographical References

Bibliography (Cite the books, articles, and other sources used in preparing this form.)

The Connecticut Forum. "Rev James Forbes Jr." October 14, 2005.

<https://www.ctforum.org/Panelist/rev-james-forbes--jr>. Retrieved 1/13/2021.

Cooper, Aimee Stone. "Means of Grace as Formative Holiness: The Role and Significance of John Wesley's Spiritual Formation Practices in The Pursuit of Christian Holiness for The Church of The Nazarene." 2016. Doctor of Ministry. Paper 142.
<http://digitalcommons.georgefox.edu/dmin/142>].

CUCC Weekly Enews. "We Welcome Rev. Dr. James A. Forbes, Jr. to our Pulpit." July 12, 2019. <http://cuccweeklynews.blogspot.com/2019/07/we-welcome-rev-dr-james-forbes-jr-to.html>. Retrieved 1/13/2021.

DuPree, Sherry S. *African-American Pentecostal Movement: An Annotated Bibliography* (Routledge) 1996.

Goldman, Ari L. "Riverside's Pastor at Center of Turmoil." May 18, 1992. *The New York Times*. Digitized version of original article at <https://www.nytimes.com/1992/05/18/nyregion/riverside-s-pastor-at-center-of-turmoil.html>.

Howard University, Andrew Rankin Memorial Chapel. "Rev. Dr. James A. Forbes." October 22, 2017. <https://chapel.howard.edu/speaker-schedule/speaker-profiles/rev-dr-james-forbes>. Retrieved 1/13/2021.

Lewes, David, and Mary Ruffin Hanbury. "First Baptist Church." National Register Nomination Form. On file at the Department of Historic Resources, Richmond, VA. 2017.

Jackson, Clyde and Helen Turnage. Interview with author, 13 Feb 2019.

Hunter, Christopher. (2016). Introduction of the Architecture of the Early Southern African American Church Building 1880 - 1920..

Jones, R. Clifford. "African American Worship: Its Heritage, Character, and Quality." *Ministry Magazine*. September 2002.
<https://www.ministrymagazine.org/archive/2002/09/african-american-worship-its-heritage-character-and-quality.html>. Retrieved 1/13/2021.

"Reverend Dr. James A. Forbes Jr's Biography," *The History Makers*, www.thehistorymakers.org/biography/reverend-dr-james-forbes-jr. Retrieved 1/3/2021

St. John's United Holy Church of America, Inc.
Name of Property

City of Richmond, VA
County and State

Ring, Deborah A. "Forbes, James A., Jr." Encyclopedia.com. No date.
<https://www.encyclopedia.com/education/news-wires-white-papers-and-books/forbes-james-jr>. Retrieved 1/13/2021.

St. John's United Holy Church, *1915-1980: 65 Years Church Anniversary Celebration, 1507 North 28th Street*. Privately published.

Sanborn Insurance Maps. Various dates.

Synan, Vinson S. *The Holiness-Pentecostal Tradition: Charismatic Movements in the Twentieth Century* (Wm. B. Erdmans) 1997, 152.

The Riverside Church in the City of New York. "Sunday, August 5, Farewell Celebration for Rev. Dr. James Forbes." <https://www.trcnyc.org/jamesforbes/>. Retrieved 1/13/2021.

Previous documentation on file (NPS):

- preliminary determination of individual listing (36 CFR 67) has been requested
- previously listed in the National Register
- previously determined eligible by the National Register
- designated a National Historic Landmark
- recorded by Historic American Buildings Survey # _____
- recorded by Historic American Engineering Record # _____
- recorded by Historic American Landscape Survey # _____

Primary location of additional data:

- State Historic Preservation Office
 - Other State agency
 - Federal agency
 - Local government
 - University
 - Other
- Name of repository: Virginia Department of Historic Resources, Richmond, VA

Historic Resources Survey Number (if assigned): DHR #127-7209

10. Geographical Data

Acreage of Property 0.575

Use either the UTM system or latitude/longitude coordinates

Latitude/Longitude Coordinates

St. John's United Holy Church of America, Inc.
Name of Property

City of Richmond, VA
County and State

Datum if other than WGS84: _____
(enter coordinates to 6 decimal places)

1. Latitude: 37.540559 Longitude: -77.405773

2. Latitude: Longitude:

3. Latitude: Longitude:

4. Latitude: Longitude:

Or

UTM References

Datum (indicated on USGS map):

NAD 1927 or NAD 1983

1. Zone: Easting: Northing:

2. Zone: Easting: Northing:

3. Zone: Easting: Northing:

4. Zone: Easting : Northing:

Verbal Boundary Description (Describe the boundaries of the property.)

The historic boundary of the nominated property coincides with the parcel identified on the tax parcel maps of the City of Richmond City as E0000790043. The true and correct historic boundary is shown on the attached Tax Parcel Map and Sketch Map & Photo Key.

Boundary Justification (Explain why the boundaries were selected.)

The boundary contains the land historically associated with St. John's United Holy Church, defining its urban context on the edge of the historic North Church Hill neighborhood, and encompasses all known historic resources associated with the property.

11. Form Prepared By

name/title: John Spain

organization: Glave and Holmes Architecture

street & number: 2101 E. Main St.

city or town: Richmond state: VA zip code: 23223

e-mail: jspan@glaveandholmes.com

telephone: 804 649-9303

date: February 7, 2020

St. John's United Holy Church of America, Inc.
Name of Property

City of Richmond, VA
County and State

Additional Documentation

Submit the following items with the completed form:

- **Maps:** A **USGS map** or equivalent (7.5 or 15 minute series) indicating the property's location.
- **Sketch map** for historic districts and properties having large acreage or numerous resources. Key all photographs to this map.
- **Additional items:** (Check with the SHPO, TPO, or FPO for any additional items.)

Photographs

Submit clear and descriptive photographs. The size of each image must be 1600x1200 pixels (minimum), 3000x2000 preferred, at 300 ppi (pixels per inch) or larger. Key all photographs to the sketch map. Each photograph must be numbered and that number must correspond to the photograph number on the photo log. For simplicity, the name of the photographer, photo date, etc. may be listed once on the photograph log and doesn't need to be labeled on every photograph.

Photo Log

Name of Property: St John's United Holy Church of America, Inc.

City or Vicinity: Richmond

County: N/A

State: Virginia

Photographer: John Spain

Date Photographed: May 1, 2019

Description of Photograph(s) and number, include description of view indicating direction of camera:

1 of 14: VA_Richmond City_St Johns UHC_0001

View: 28th Street entrance, looking southwest.

2 of 14: VA_Richmond City_St Johns UHC_0002

Exterior Detail:.Tuscan entrance portico facing 28th Street, looking south.

3 of 14: VA_Richmond City_St Johns UHC_0003

View: Northeast side, looking west. The addition begins to the left of the downspout near the tall chimney.

4 of 14: VA_Richmond City_St Johns UHC_0004

View: Southwest side, looking north. The addition begins three bricks to the left of the door.

St. John's United Holy Church of America, Inc.
Name of Property

City of Richmond, VA
County and State

5 of 14. VA_Richmond City_St Johns UHC_0005
View: Sanctuary interior, looking southeast.

6 of 14. VA_Richmond City_St Johns UHC_0006
View: Sanctuary interior, looking northwest.

7 of 14. VA_Richmond City_St Johns UHC_0007
View: Assembly Hall, looking northwest.

8 of 14. VA_Richmond City_St Johns UHC_0008
View: Kitchen, looking southeast.

9 of 14. VA_Richmond City_St Johns UHC_0009
View: Addition Basement, looking northwest. The brick wall is the original building.

10 of 14. VA_Richmond City_St Johns UHC_0010
View: Assembly Hall, looking southeast.

11 of 14. VA_Richmond City_St Johns UHC_0011
Exterior Detail:.Bull's eye window facing 28th Street, looking southeast.

12 of 14. VA_Richmond City_St Johns UHC_0013
Exterior Detail:.Window with moldings and cornice facing 28th Street, looking southeast.

13 of 14. VA_Richmond City_St Johns UHC_0014
Interior Detail:.Ceiling pattern at perimeter, anthemion frieze, architrave at window.

14 of 14. VA_Richmond City_St Johns UHC_0015
Interior Detail:.Ceiling central square and typical stylized nine-square pattern.

Index of Figures

1. 1925 Sanborn Fire Insurance Map, Richmond VA. It shows the original church of 1915.
2. 1950 Sanborn Fire Insurance Map, Richmond VA. It shows the church of 1931, with the furnace room extending to the rear.
3. Anthony H. Andrews and J. B. Wooding, Existing Floor Plans, St. John's United Holy Church. No date (c. 1950) [St. John's United Holy Church]. These plans were drawn as part of the planning for the rear addition. They document the form of the church before the addition.

St. John's United Holy Church of America, Inc.
Name of Property

City of Richmond, VA
County and State

4. Anthony H. Andrews and J. B. Wooding, Detail, Proposal for Phase I of alterations and east end addition at St. John's United Holy Church, no date (c 1950) [St. John's United Holy Church, Inc.].

Paperwork Reduction Act Statement: This information is being collected for applications to the National Register of Historic Places to nominate properties for listing or determine eligibility for listing, to list properties, and to amend existing listings. Response to this request is required to obtain a benefit in accordance with the National Historic Preservation Act, as amended (16 U.S.C.460 et seq.).

Estimated Burden Statement: Public reporting burden for this form is estimated to average 100 hours per response including time for reviewing instructions, gathering and maintaining data, and completing and reviewing the form. Direct comments regarding this burden estimate or any aspect of this form to the Office of Planning and Performance Management, U.S. Dept. of the Interior, 1849 C. Street, NW, Washington, DC.



LOCATION MAP

St. John's United Holy Church of America, Inc.

City of Richmond, VA

DHR No. 127-7209

Latitude/Longitude Coordinates

Latitude: 37.540559

Longitude: -77.405773

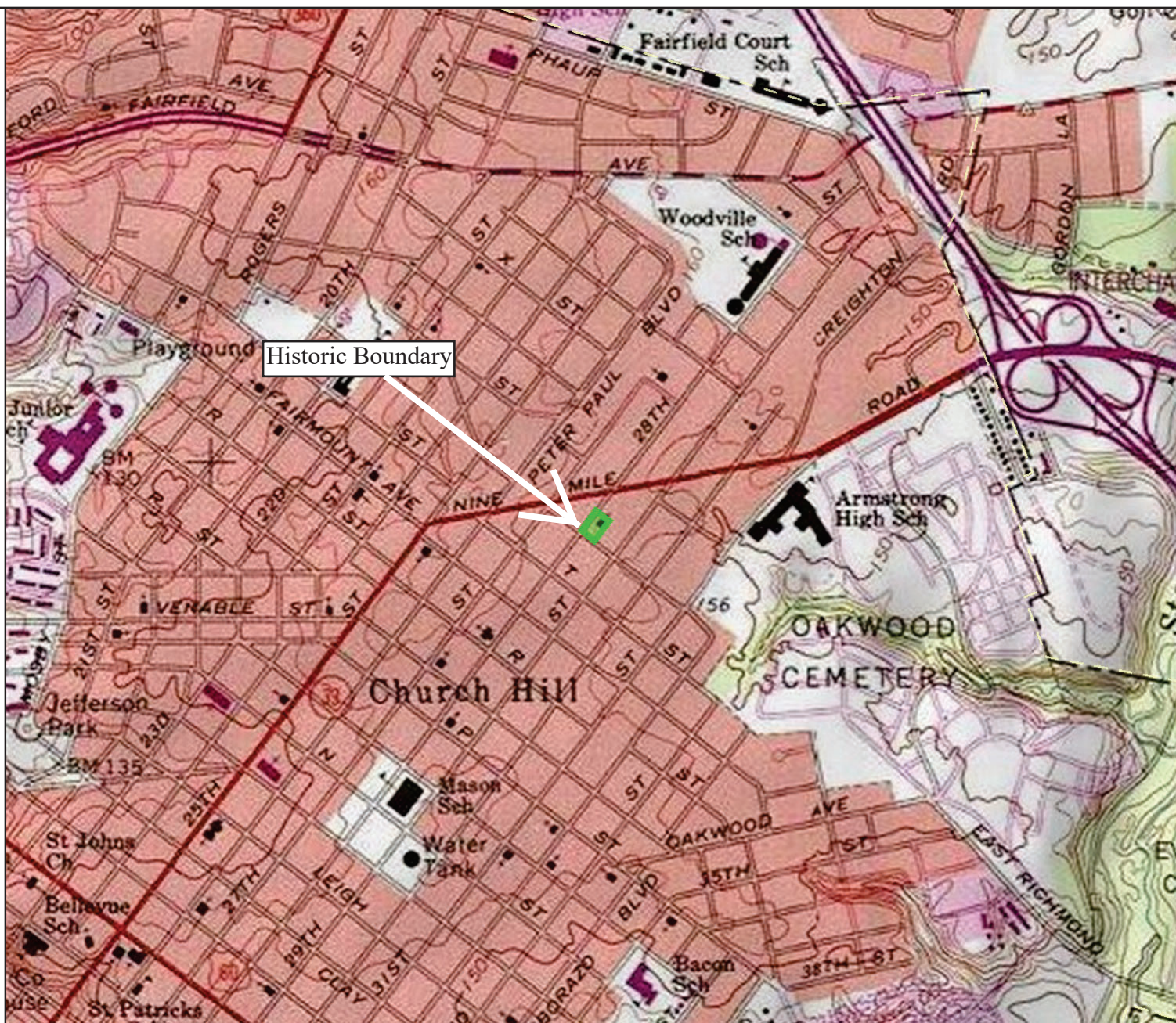

Feet

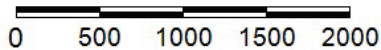

1:18,056 / 1"=1,505 Feet

Title:

Date: 1/13/2021



DISCLAIMER: Records of the Virginia Department of Historic Resources (DHR) have been gathered over many years from a variety of sources and the representation depicted is a cumulative view of field observations over time and may not reflect current ground conditions. The map is for general information purposes and is not intended for engineering, legal or other site-specific uses. Map may contain errors and is provided "as-is". More information is available in the DHR Archives located at DHR's Richmond office.

Notice if AE sites: Locations of archaeological sites may be sensitive the National Historic Preservation Act (NHPA), and the Archaeological Resources Protection Act (ARPA) and Code of Virginia §2.2-3705.7 (10). Release of precise locations may threaten archaeological sites and historic resources.

Aerial View



1/12/2021, 3:36:36 PM

-  CityBoundary
-  Parcels

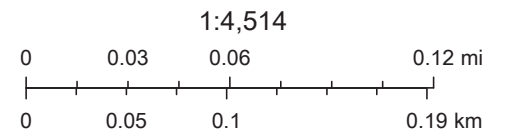

SKETCH MAP AND PHOTO KEY (exterior)



St. John's United Holy Church of America, Inc.
 City of Richmond, VA 23223; DHR #127-7209

Church - contributing building

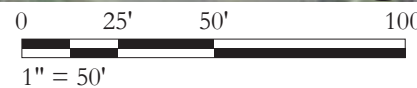

Interior Views:

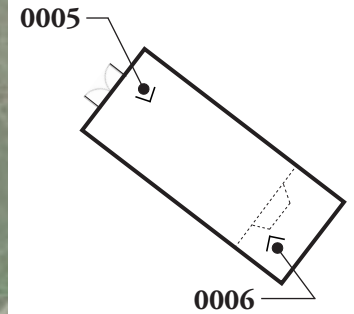

Assembly Hall
Upper Level

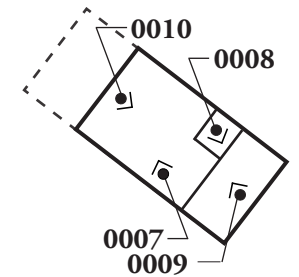

Assembly Hall
Lower Level

Photo Locations ← 0001



Richmond Parcel Mapper
<https://cor.maps.arcgis.com/apps/webappviewer/index.html?id=c3ed34c0fb38441fb95cd2d2d6a22d48>
 Accessed 1/12/2021

TAX PARCEL MAP

St. John's United Holy Church of America Inc.
 City of Richmond, VA 23223
 DHR #127-7209



Site #: 127-7209
 Latitude: 37° 32' 26" N
 Longitude: 77° 24' 21" W